

Design And Implementation of Automotive ECU Programming System Based on The Principle of Wi-Fi Remote Communication

Lu Junwei¹, Gong Yuanming², Zhou Jianpeng³, Li Wenjing⁴

(College Of Automotive Engineering, Shanghai University Of Engineering And Technology, Shanghai 201620, China)

Abstract: Traditionally, programming ECU requires frequent burner plugged and unplugged, which means workload, and simultaneously programming a plurality of ECU can not be carried out, debugging efficiency is also low because of these problems. On the basis of Wi-Fi wireless communication theory and a platform of Visual Studio C# software development tools and Infineon XC2000 Family MCU - XC2234L, We developed a set of car ECU remote programming system. The programming system can achieve efficient batch programming the ECU, as opposed to the conventional method in terms of more convenient, fast and efficient.

Keywords: Wi-Fi, Visual Studio C#, Automotive ECU, Remote Programming

I. INTRODUCTION

In recent years, along with the gradual deepening of the information and the degree of electron, the concept of the Internet of things is gradually clear. governments at all levels of China issued a series of policies in this regard to be encouraged and supported, all of which make the prospects of the application of the Internet of things be more broad^[1]. ECU is considered to be the core parts of the automobile and the programmer of it has been part of priority among priorities. The traditional method requires frequent plugging operation, heavy workload, extremely inconvenient and a PC only to a burner burning write, not at the same time to multiple burner burning write and makes debugging operation inefficient problem etc^[2]. The automobile ECU burning system we develop is achieved on the basis of Wi-Fi wireless communication theory and a platform of LabVIEW software development tools and Infineon XC2000 Family MCU - XC2234L. Programming and debugging can not only avoid frequent plugging operation, is simple and convenient to use, stable and reliable to operate, but also can realize the batch burn and greatly reduce the workload, bringing great convenience for the personnel engaged in related work.

II. OVERALL SYSTEM DESIGN

The structure of the system that is shown in **Fig1**, is composed of ECU remote car burning system service center and client. 802.11 standard defines two working modes, ad hoc mode and the infrastructure mode, often said that the point to point mode, the mode don't need the support of any infrastructure and can set up communication between sites within the scope of the coverage; and infrastructure is the AP mode, structure at least comprises a wireless access point (AP), wireless site by AP and existing backbone connected a basic service set (BSS). In BSS, all sites use the same radio frequency, AP not only provides a wireless site communication between the bridge function, but also provides the connection between the wireless station and wired LAN^[3].

This paper mainly studies the design of Wi-Fi wireless terminal node and access point. Wi-Fi wireless terminal through the CAN bus establish communication with ECU. Wireless access points through the wireless way transmit data to the Wi-Fi wireless terminal, the wireless terminal will receive the data and then through the protocol conversion send to ECU by the CAN bus. The hardware structure of Wi-Fi wireless terminal node and the design of embedded software are explained in detail in this paper.

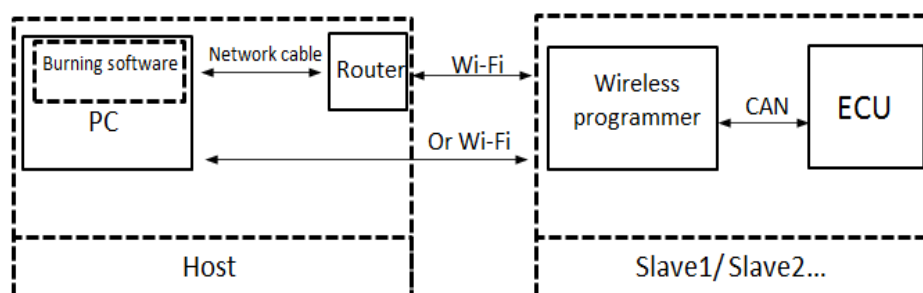

Fig1: The structure of the system

III. HARDWARE CIRCUIT DESIGN OF THE SYSTEM

The wireless programmer(Wi-Fi terminal node)can communicate with ECU through the CAN bus, the hardware mainly includes: Core processor, 12V to 5V adjustable voltage circuit, Wi-Fi to serial module(SDZ06), CAN communication module with isolation,LED indicator light, reset circuit. The hardware structure diagram is shown in

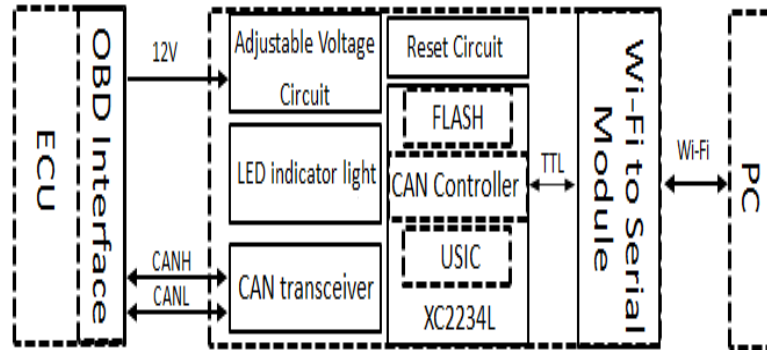

Fig2: The Structure of the System

Wireless programmerwas developedon the basis of the Infineon XC2000 Family MCU--XC2234L.Peripheral module function of the MCU is more powerful, and not only integrates the universal serial interface module USIC, but also integrates full CAN function multi-CAN module [4]. Using the MCU can greatly simplify the hardware circuit design, so as to meet the requirements of the design of flexible and changeable shape structure. Wi-Fi wireless module uses the Wi-Fi to serial module SDZ06 of Shun Zhou Technology Co., Ltd.Wireless programmer is directly powered by ECUthrough the OBD interface.

IV. SOFTWARE DESIGN OF THE SYSTEM

The wireless programmer software architecture consists of two parts: the bootloader and the main program of the function.

4.1 The transplantation of bootloader

In order to meet the needs of a variety of ECU program update,It is very necessary to transplant bootloader to the wireless programmer.According to the size of the bootloader,the system is divided into three regions: 0xC01000 to 0xC0DFFF flash space store bootloader program;0xC10000to 0xCCFFFFflash space store system applications;0xC0F000 to 0xC0FFFF is to be reserved ; In addition , the0xC0E000 to 0xC0EFFFflash space as an information recording area, you can store hardware serial number, software version, as well as other information needs to be saved[5]. The specific circumstances of the Flash partition are shown in Fig3.

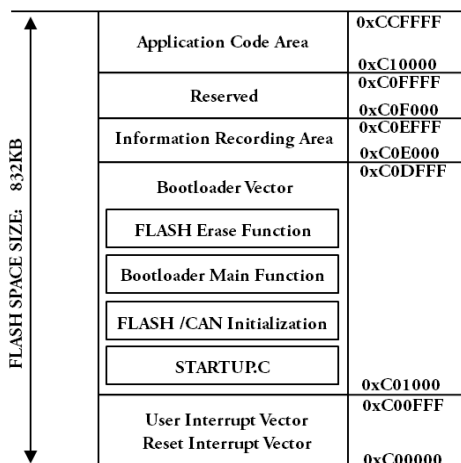

Fig3: Flash Partition

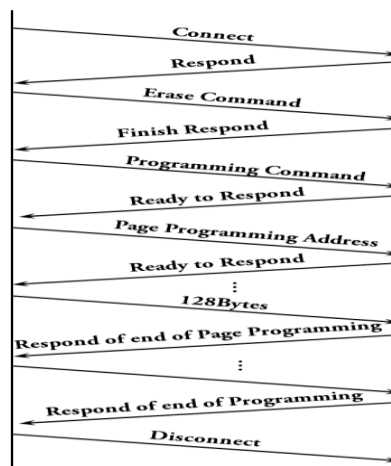

Fig4: The System Workflow

Exit address of reset interrupt vector is 0xC01000. Therefore, after the start of the microcontroller on the power or software to restart, it firstly jumps to STARTUP.C. Decide whether to jump or not by judging whether the upgrade flag is set. Set means there is an upgrade request and execute the Bootloader initialization. After that, it begins to execute the main function and erase the flag of upgrade after the success of upgrade. if there is not an upgrade request it will jump to user program sector to execute the user software. When the user software is updated, it is necessary to update interrupt vector at the same time, which make sure that it makes it possible to use interrupt function for user program.

4.2 The Main Program of The Function.

The main program of the function is mainly consisted of Command resolution program and write subroutine based on CCP. Command parsing program is mainly used to receive commands from the host computer to send the order and execute the command. After the completion of the system connection, the host computer could load the application file that needs to update. Click the "START" button, the online programming system will start, the system workflow as shown above Fig4.

In this paper, we use the method of increasing the status of the upgrade^[5]. When the user program is running, if there is a request to upgrade the status of the microcontroller will identify the location of the status, and restart the software. After the restart, the microcontroller firstly detects the status flag .if there is an upgrade request, it will enter the Bootloader to upgrade software. If the error occurs and leads to the upgrade is not complete in the process of upgrading, upgrade mark will not clear, MCU after the restart still enter bootloader that operate directly on the host computer programming button to enter the program to upgrade the operating. This method can effectively solve the problem of the failure of the upgrade process and the waiting problem of the handshake.

V. VERIFICATION AND CONCLUSION

We choose the independent research and development of ECU as test object, the ECU is developed based on Infineon xc2000 family MCU-XC2765. CAN bootloader has been preloaded in its internal, so we can change the startup mode through software set, so as to realize the ECU main program XC2765 app update. After completing the connection of the physical circuits of the system, we can start ECU and configure client IP address and port, open the host computer programming software that was developed through Visual Studio C#. Once Network connection would be created, you can load hex file to execute remote programming operation. Programming interface is as follows Fig5.

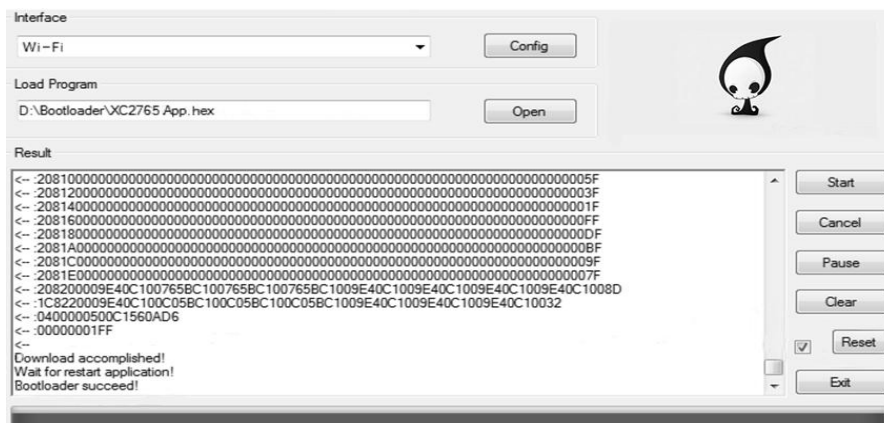

Fig5: Programming interface

After testing , Upper machine have good and stable connection with the lower machine.wireless burner work reliably and have good performance. The whole recording process only need tens of seconds to complete. The application of wireless burner is not limited to update ECU main program, we can also develop a multi-purpose tool with parameter calibration , fault diagnosis and remote programming. In addition, in order to achieve small batch burn of ECU, we can add device in the connection configuration interface on PC.

REFERENCES

- [1]. Zhu Hongbo, Yang Longxiang. Progress and application of the Internet of things technology [J]. Journal of Nanjing University of Posts and Telecommunications (NATURAL SCIENCE EDITION), 2011, thirty-first volumes (1): 2-3.
- [2]. Zhang Zhijun, Xu Xiaoli. Wireless data acquisition system based on LabVIEW and Wi-Fi technology [J]. chemical automation and instrumentation, 2012, fortieth volumes (3): 368-369.
- [3]. Zeng Lei, zhanghaifeng. design and implementation of monitoring system Based on Wi-Fi wireless Communication [J]. Electrical measurement & instrumentation, 2011, Vol. 48 (3): 81-83.
- [4]. Cheng Ximing. Embedded Microcontroller Unit for Automotive Applications (PUBLISHING HOUSE OF ELECTRONICS INDUSTRY, 2013)
- [5]. Shao Hui Zhu, Xia Chaoying. ECU online programming based on CAN bus [J]. Microcontroller & embedded systems, 2014, the 48 volume (1): 24-27.